



TWS
Trinity Wireless Solutions LLC



Quick Start Guide

RF over Fiber Tester

Version: 1.0

Date: 1-26-2026



TWS
Trinity Wireless Solutions LLC



Product Introduction

The TWS RF over Fiber Tester (RFFT) allows technicians and engineers to analog RF over fiber (RFoF) transceivers. The intent of the product is to allow for the insertion or extraction of RFoF signals from installed equipment. It is useful for troubleshooting systems with RFoF transmitter or receivers, allowing for isolating failures in either the optical and RF circuits of the unit under test.

The RFFT is designed to be used with a spectrum analyzer that has a tracking generator function, or at a minimum an RF continuous wave generator, and a RF spectrum analyzer. If only optical circuitry is being tested then the RFFT can provide go-no go indications with its LEDs.

The RFFT provides the following functions:

1. Detects and indicates the presence of an optical signal in the 1300 or 1500 nm bands

Note: The receiver path is broadband, it works for all wavelengths in the supported range, this is the reason there is only a single receiver input port and a single output port.

2. Extracts the RF signal from analog RFoF modulated optical signals in the 1300 or 1500 nm bands
3. Generates optical carriers at 1310, 1490, 1510, 1530, and 1550 nm wavelengths.
4. Accepts an RF input signal up to +10 dBm, modulates the signal on an optical carrier at 1310, 1490, 1510, 1530 or 1550 nm, allowing for full optical and RF circuitry test of RF over fiber receivers.
5. Allows for RFoF wavelength shift from any wavelength in the 1300– 1500 nm bands to 1310, 1490, 1510, 1530, or 1550 nm.

The RFFT integrates Optical Zonu brand RF over Fiber transmitters and receivers internally, it is designed to support all the wavelengths used by Optical Zonu.

Product Safety Precautions

This product contains lasers that emit invisible light. Lasers are inherently dangerous and can cause eyesight damage or eyesight loss. Always be aware of the dangers associated with lasers before operating this product. The five ports labelled “TX” on the front panel are all laser transmitter outputs. The product ships with covers for these ports, these should be kept with the product to safely cover the transmit ports when not in use.

These are some good safe practices:

1. Always only uncover the TX ports that are in use for testing, then re-cover the port once it is no longer being used.
2. Always terminate the optical port on the front panel with an optical patch cable to the device under test before applying optical energy with the laser on switch.
3. Always utilize the laser on/off switch on the rear panel to turn off all the lasers when not needed.



TWS
Trinity Wireless Solutions LLC



4. Always confirm the laser on/off switch is in the off position before applying power to the unit and after you are done using it.

These are some unsafe practices that should never be done:

1. Never purposefully look into an exposed optical port on the front panel with the device on. If inspection is deemed necessary, always remove power first.
2. Never use binoculars or other optical magnification devices around this or any energized optical generation device, the invisible light from these devices is still magnified just like the light you see, this increases risk of over exposure.

The device is Class 1 eye safe, so the risk of eye damage is relatively low compared to more powerful lasers. Nevertheless, the above precautions are still the best practice when operating this or any laser equipment.

What's In the Box?

The kit contains:

1. Carrying case
2. RFFT device
3. AC adapter (120VAC to 12VDC)
4. SMA to SMA RF test cable
5. SC-APC to SC-APC optical patch cable

Connections and Controls

Power Connector

The power connector is a 2 position terminal that accepts a screw lock plug. The correct plug is pre installed on the supplied AC adapter.

Power Switch

The power switch is on the back of the unit. The power switch illuminates green when power is applied to the RFFT. The green illumination will be present even when the device is turned off. If there is no illumination on the power switch confirm that the AC adapter is plugged in on both ends and that AC is present.

To turn the RFFT on, depress the illuminated side of the power switch.

Laser Switch

The Laser switch is on the back of the unit. The laser switch illuminates green only when the lasers are tuned on. The laser switch turns on all five front panel laser ports at once. There is no way to control each port individually except by leaving them covered with the supplied caps. When the laser switch is turned on, the laser switch should illuminate and all five front panel TX



TWS
Trinity Wireless Solutions LLC



port LEDs should also illuminate. If any of these do not light up there is an issue with the device that requires the manufacturers attention.

RFoF TX Paths

There are five, nearly identical RFoF transmit paths on the front panel. The only difference between them is the wavelength of the light, all other aspects are the same. The function of the TX path is to accept an RF signal on the input, modulate it onto the associated light wave, and expose the modulated optical signal at the output. Each TX path includes an RF input port, an LED indicator, and an optical output port. All these ports are arranged vertically with the RF port on the top and the optical port on the bottom.

LED OFF – Indicates that the TX path is off, no laser signal present, applying an RF signal at the input will not result in a signal on the output. Turn the Laser switch on to turn the TX paths on.

GREEN LED – indicates that the laser is on and transmitting optical energy.

RED LED – indicates that the laser power is not present or below threshold, this should never occur in normal operation, if it does this indicates an internal failure of the RFFT requiring manufacturer attention.

- All TX paths are independent of one another.
- Applying RF energy on one Rf input port will result in modulated RFoF energy only on the optical port associated with the same path.
- The TX paths are one way. Applying an RFoF modulated optical signal to the TX path output port will not result in RF energy on the input port. It will do nothing and could cause damage.

Warning: Never plug the optical port of one TX path to the optical port of another TX path. This will not do anything useful and could cause damage.

You may safely plug the optical port of a transmit path to the input port of the receiver path.

RFoF RX Path

There is one RFoF receiver path. The function of the RX path is to accept a modulated RFoF signal on the input, extract the RF signal from the Lightwave, and expose the RF signal at the output. The RX path includes an optical input port, an LED indicator and an RF port.

LED OFF – Indicates that the RX path is off and cannot convert RFoF energy to RF energy, applying an optical signal at the input will not result in an RF signal on the output. Turn the power switch on to enable this path.

GREEN LED – indicates that the receiver is on and receiving optical energy (not necessarily an RFoF signal). The optical signal must be greater than -10 dBm (optical power) to turn the LED green.



TWS
Trinity Wireless Solutions LLC



RED LED – indicates that the laser power is not present or below the -10 dBm threshold. This could happen if there is excessive loss the RFoF link. A red LED does not necessarily mean that there will be no RF power on the output, optical energy below -10dBm will still be converted to RF, but the power level will be low due to low optical power, and the signal will be closer to the noise due to a fixed output noise level (independent of signal level).

- There is only one RFoF RX path.
- The RFoF RX path works for ALL supported wavelengths.

Turn On Instructions

To turn on the RFFT use the following steps:

1. Remove the RFFT from the transit case.
2. Confirm that the power and laser switches are in the off position (toggled such that the non illuminated side of the switch is pressed down).
3. Connect the green power plug on the supplied AC adapter to the rear panel.
4. Plug the AC adapter into a 120VAC wall socket.
5. Confirm that the power plug on the rear panel is lit up green.
6. Switch the power on.
7. Plug in the desired connections on the front panel and ensure that any unused fiber connections remain covered.
8. Toggle the laser switch on, confirm that the laser switch illuminates and that all laser path LEDs on the front panel illuminate green.

At this point the device is ready to convert RF energy into RFoF energy or to receive RFoF energy and convert it back to RF.

Note: If the desired test only requires RFoF reception and conversion back to RF, then the laser switch can remain in the off position.

Example Test Configurations:

These are some examples of test configurations that might be useful.

Testing the TRANSMIT PATH of an Optical Zonu RFoF transmitter or transceiver

Device under test: RFoF transmitter or transceiver

Path being tested: RFoF transmit path

Relevant RFFT path: RFoF RX

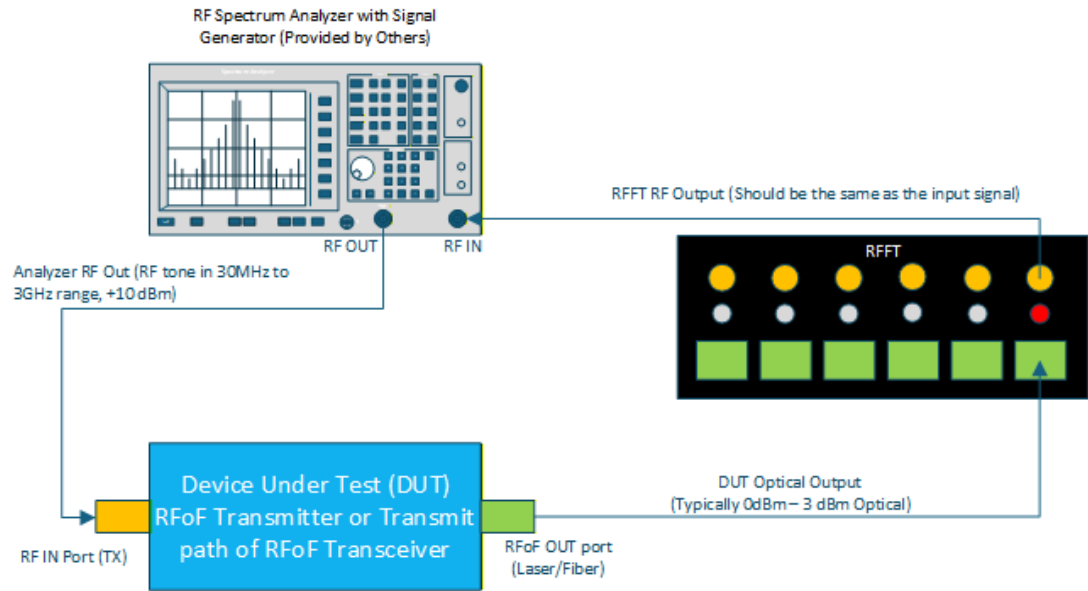

Figure 1 RFoF Transmitter Test

For the test configuration in figure 1, the expected output RF level is found by the following simple equation:

$$RFLevel = +11 \pm 2 \text{ dB} - 2 * (\text{optical loss in dB})$$

For example, if a small optical jumper is used like the one provided in the kit, then the optical loss is almost 0 dB. In this case the RF power out of the RFFT with a 10 dBm input signal will be 9-13 dBm. If the measurement is taken at the end of a long fiber run with 5 dB of loss then the signal would be -1 to +3 dBm due to the optical loss.

Testing the RECEIVE PATH of an Optical Zonu RFoF receiver or transceiver

Device under test: RFoF receiver or transceiver

Path being tested: RFoF receive path

Relevant RFFT path: RFoF TX

Note: When using the RFFT to test a RFoF receiver device, it is important to be aware of any wavelength division multiplexing filters that may be present in the RFoF device under test. The part number of the device under test will often tell you what wavelength to use. Consult the RFoF module datasheet to confirm the proper wavelength for the test, or in a pinch try to use all five transmitter paths provided on the RFFT until one of them works.

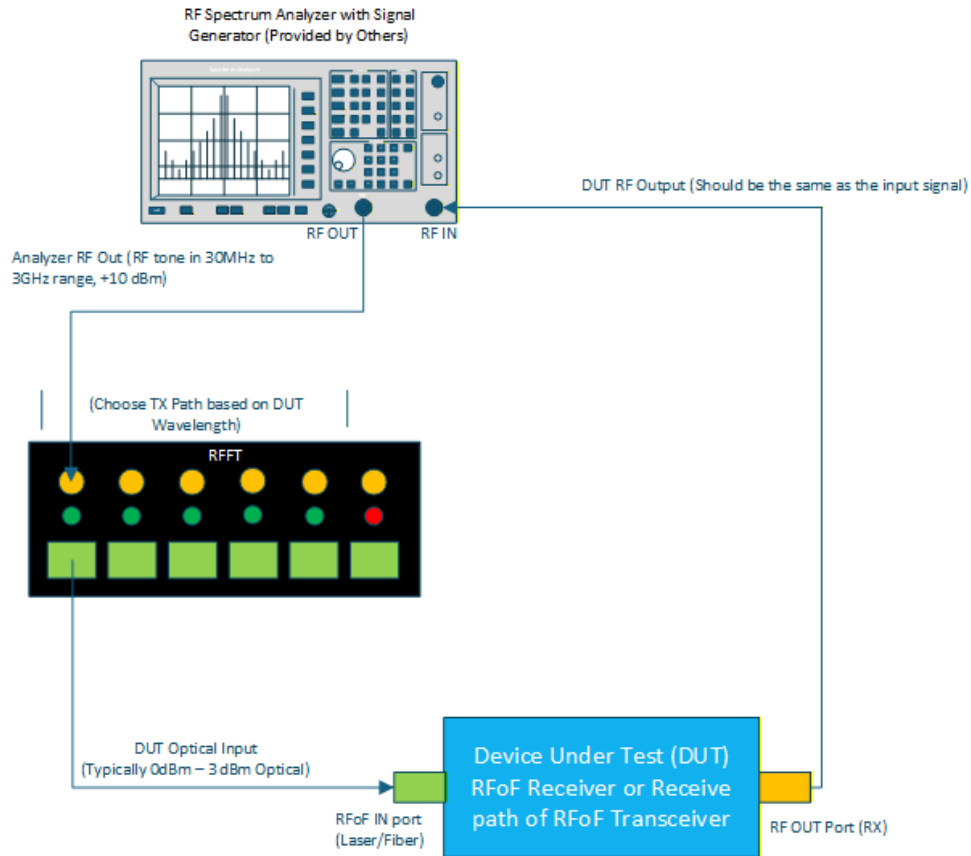

Figure 2 RFoF Transmitter Test

For the test configuration in figure 2, the expected output RF level is found by the following simple equation:

$$RFLevel = +11 +/- 2 dB - 2 * (optical loss in dB)$$

For example, if a small optical jumper is use like the one provided in the kit, then the optical loss is almost 0 dB. In this case the RF power out of the RFFT with a 10 dBm input signal will be 9-13 dBm. If the measurement is taken at the end of a long fiber run with 5 dB of loss then the signal would be -1 to +3 dBm due to the optical loss.

RFFT Loopback Test:

Device under test: RFFT Self Test

Path being tested: RFFT TX path and RFFT RX path

Relevant RFFT path: As above



It is possible to “self test” the RFFT. To accomplish this, connect as shown in figure 3. Only one transmit path can be used at a time, but it does not matter which one you choose. This test can be used to confirm the RFFT as a “known good” before using it to test a DUT.

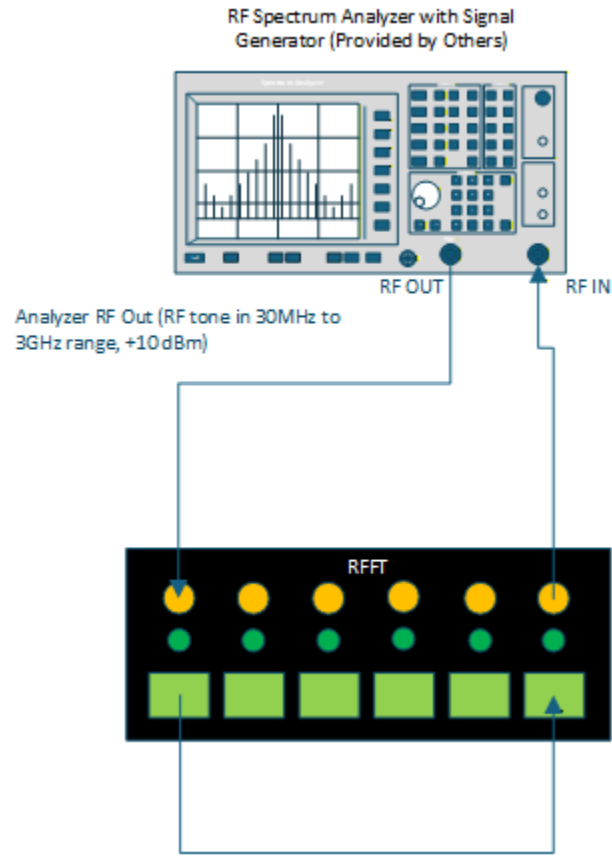

Figure 3 RFFoF Loop Back Test

For the test configuration in figure 2, the expected output RF level is found by the following simple equation:

$$RFLevel = +11 \pm 2 \text{ dB}$$

For example, if a small optical jumper is use like the one provided in the kit, then the optical loss is almost 0 dB. In this case the RF power out of the RFFT with a 10 dBm input signal will be 9-13 dBm. It is assumed that only a small jumper will be used for this test (minimal loss).

END OF DOCUMENT